

CLIPS NO	X	W	Weight (Kg)
BEKET 4021	21	44	0,650

### TECHNICAL SPECIFICATIONS

- Max side load 70 kN
- Lateral adjustment 8 mm
- Bolt M20 Grade 8.8
- Tightening Torque 320 Nm
- Steel Quality St52-3

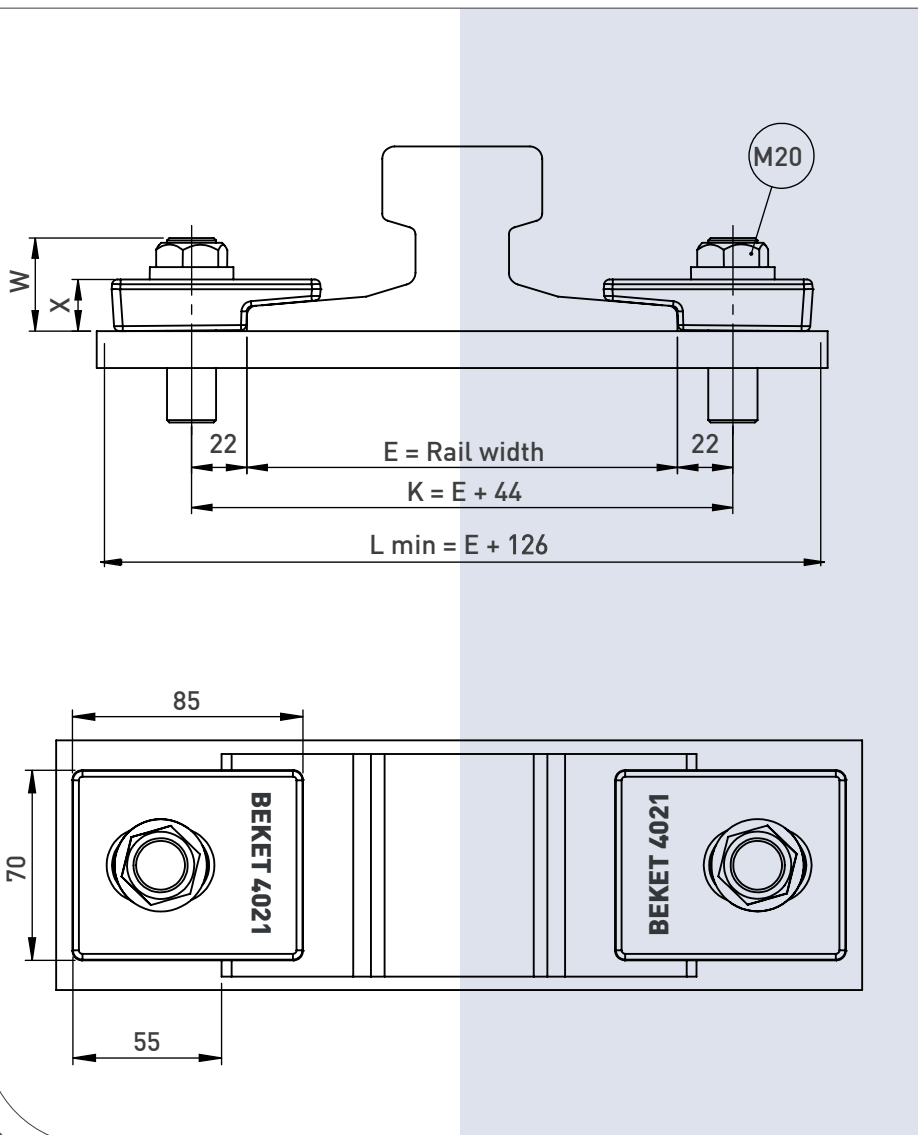

### MAIN FEATURES

- 1- BEKET 4021 bolted rail clip, which is produced from a forged part, enables ease of assembly thanks to its special design.
- 2- The clips can be preferred for rails with or without pads.
- 3- The main part is locked to rail with M20 bolt.

- Flange nut can also be used on request. Please consult us for using flange nut.

# 4021

## Beket 4021 Bolted Rail Clips

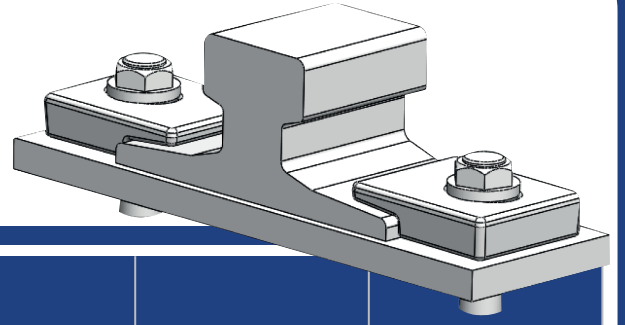

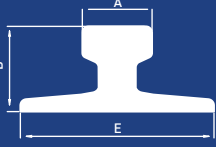
	A	B	E	Without Pad	With Pad
A45	45	55	125	-	-
A55	55	65	150	-	-
A65	65	75	175	4021	-
A75	75	85	200	4021	-
A100	100	95	200	-	-
A120	120	105	220	-	-
A150	150	150	220	-	-
S10	32	70	58	-	-
S14	38	80	70	-	-
S18	43	93	82	-	-
S20	44	100	82	-	-
S24	53	115	90	4021	-
S30	60,3	108	108	4021	-
S31	56	125	106	-	-
S33	65	145	135	4021	-
S41 A	67	138	125	4021	-
S49	67	149	125	4021	-
54 E1 (UIC54)	70	159	140	4021	-
60 E1 (UIC60)	72	172	150	-	-

Clip can be with more type of rails than those listed.

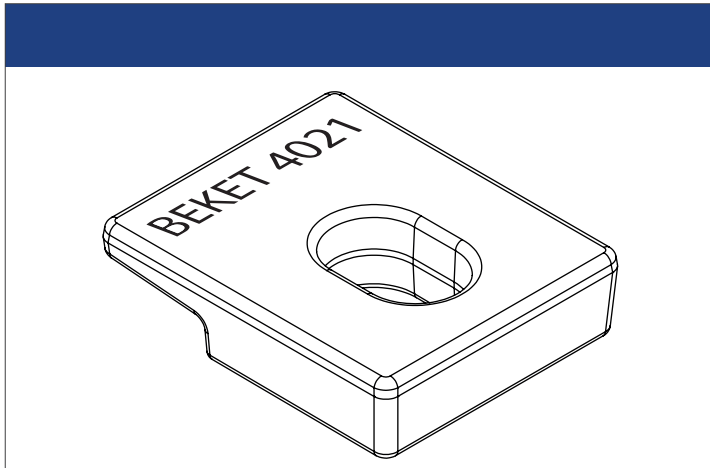

### INSTALLATION INSTRUCTIONS:

The main component is first positioned on the bolt against the rail and the special washer is then positioned on the main component. The nut is hand tightened. Hammer is used for tighter contact. The main component is in position, use an electrical or pneumatic wrench to torque the nut. Please contact BEKET for full installation instructions.

