

CLIPS NO	X	C	W	N	Weight (Kg)
BEKET K 16K /33/10	23	33	50	10	0,825
BEKET K 16K /33/14	23	33	50	14	0,845
BEKET K 16K /33/18	23	33	50	18	0,865
BEKET K 16/39/12	23	39	50	12	0,870
BEKET K 16/39/18	23	39	50	18	0,880
BEKET K 16/39/23	23	39	50	23	0,890

TECHNICAL SPECIFICATIONS

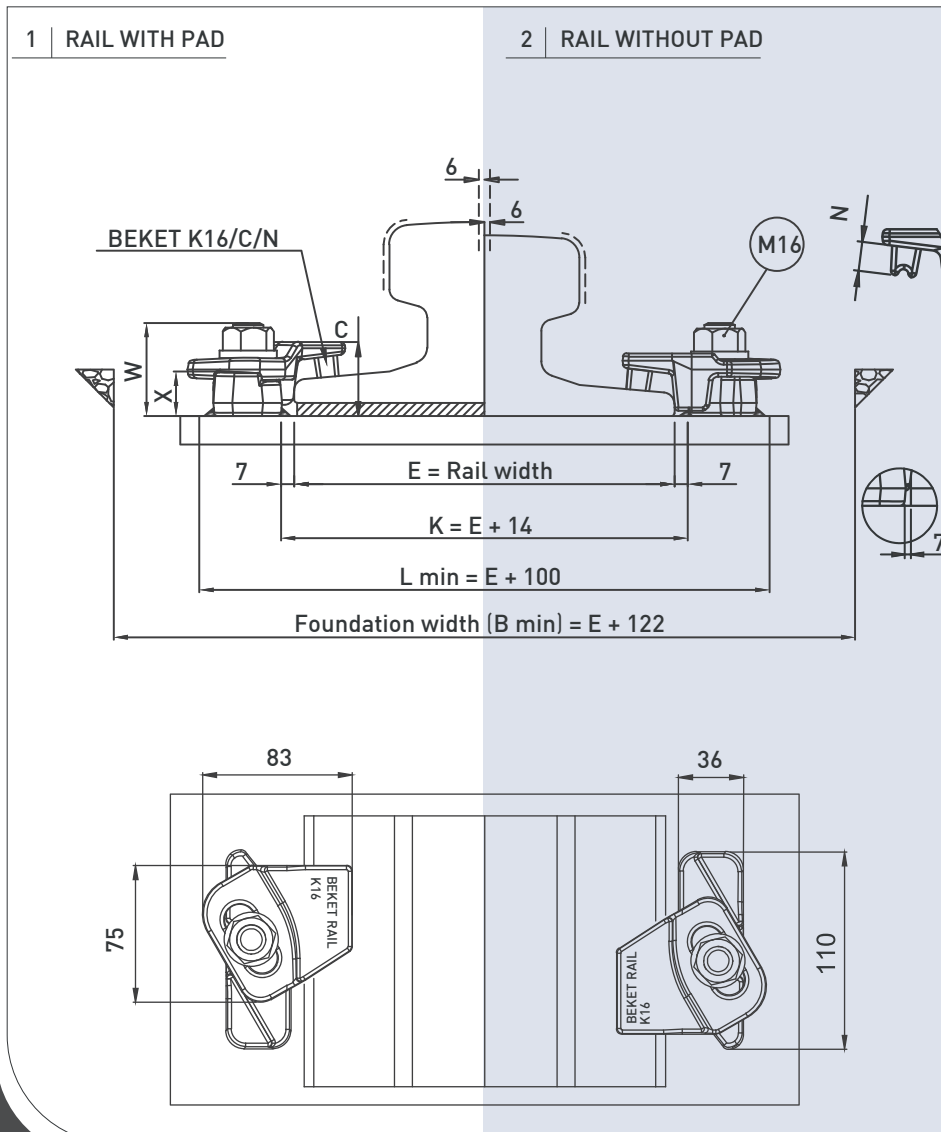

- Max side load 140 kN
- Lateral adjustment 12 mm
- Bolt M16 Grade 8.8
- Tightening Torque 200 Nm
- Steel Quality St52-3



MAIN FEATURES

1. BEKET K 16 welded rail clips, which are produced from 2 forged parts as upper and lower enables ease of assembly thanks to its special desing.
2. The clips can preferred for rails with or without pads.
3. The two main parts are locked together with special bolt.
4. The rubber nose increases the tolerances of the rail support structures, reduces the stress of the connections, allows a better fixing of the rail.

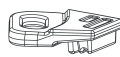
COMPONENTS

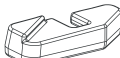
-  ① Nut and washer M16
-  ② Upper part with rubber nose
-  ③ Special bolt M16
-  ④ Weldable lower part

- Flange nut can also be used on request. Please consult us for using flange nut.

K16

Beket K16 Welded Rail Clips

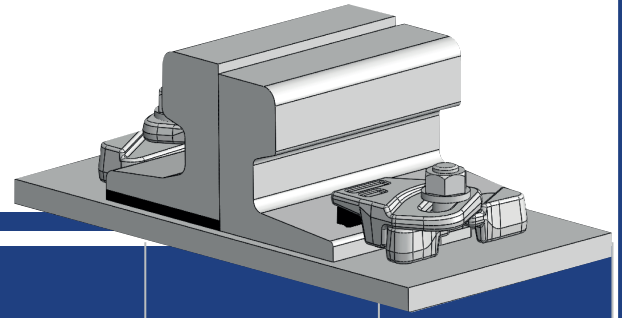

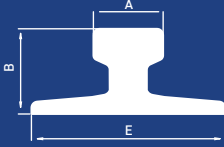
	A	B	E	Without Pad	With Pad
A45	45	55	125	K16 K/33/18	K16 K/33/14
A55	55	65	150	K16 K/33/18	K16 K/33/14
A65	65	75	175	K16 K/33/18	K16 /39/18
A75	75	85	200	K16 K/33/18	K16 /39/18
A100	100	95	200	K16 K/33/14	K16 /39/18
A120	120	105	220	K16 K/33/14	K16 /39/12
S30	60,3	108	108	K16 K/33/18	K16 /39/18
S33	58	134	105	K16 K/33/18	K16 /39/18
S41A	67	138	125	K16 K/33/18	K16 /39/18
S49	67	149	125	K16 K/33/14	K16 /39/18
S54	67	154	125	K16 K/33/14	K16 /39/12
UIC54	70	159	140	K16 K/33/14	K16 /39/18
UIC60	72	172	150	K16 K/33/14	K16 /39/18
P50	72	152	132	K16 K/33/14	K16 /39/12
P65	73	180	150	K16 K/33/14	K16 /39/12
KP70	70	120	120	K16 K/33/14	K16 /39/18
KP80	80	130	130	K16 K/33/14	K16 /39/18
KP100	100	150	150	K16 K/33/14	K16 /39/18
KP120	120	170	170	K16 /39/18	K16 /39/18

Clip can be with more type of rails than those listed.

WELD DETAIL

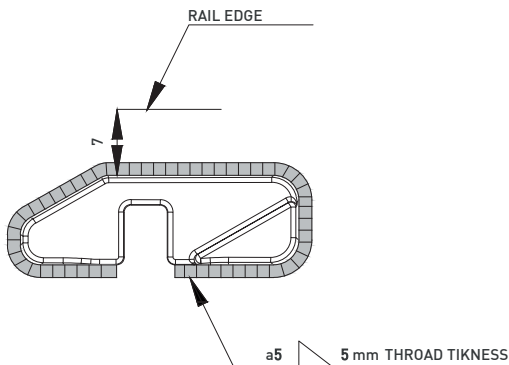

INSTALLATION INSTRUCTIONS:

Weld all round the clip base, except the side closest and parallel to the rail with a 5 mm throat thickness fillet weld, using low hydrogen electrodes. Recommended electrodes AWS E7018 or E7028. Clip base is made from weldable grade steel. Please consult us for continuous welding requirement.

ELEKTRODE

AWS A5.1 1-04 E7018-1
EN ISO 2560-A E42 4 B42 H5
CE EN 13479

ROD

AWS A5.18 ER 70S-6: S63
EN ISO 1668 W 4Si1: S63



Deutsche
Akkreditierungsstelle
D-ZM-12007-01-00



TÜRKAK BDS NO
Y5-2809-9621